

右向端面圓槽刀 Right hand end face radius turning tool

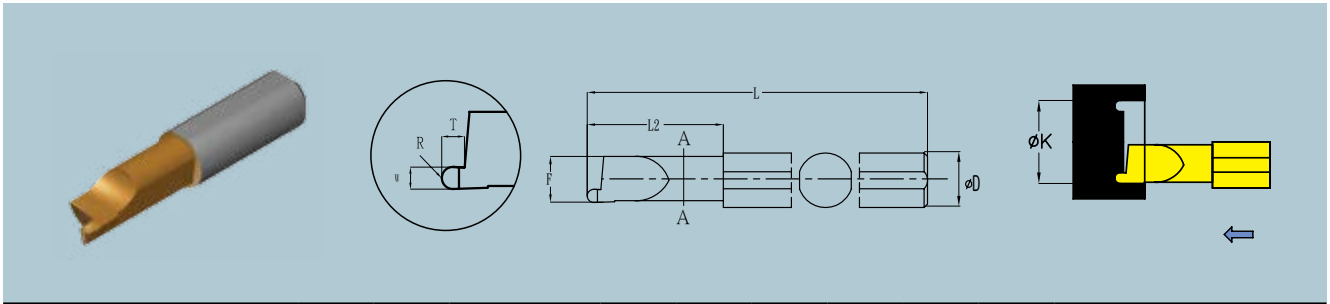

型號 EDP NO.	ØK	F	R±0.03	T	L2	L	r	ØD	H	在庫 stock	適用套筒 Applicable Sleeve
B73.6020-050R	6	5.8	1.0	2.0	20	55	0.5	6	5.5	●	SP.250-06** SP.5650-06**
B73.6020-075R	6	5.8	1.5	2.0	20	55	0.75	6	5.5	●	
B73.6020-100R	6	5.8	2.0	3.0	20	55	1.0	6	5.5	●	
B73.8025-050R	8	7.8	1.0	2.0	25	65	0.5	8	7.3	●	SP.250-08** SP.5650-08**
B73.8025-075R	8	7.8	1.5	3.0	25	65	0.75	8	7.3		
B73.8025-100R	8	7.8	2.0	3.0	25	65	1.0	8	7.3		
B73.8025-125R	8	7.8	2.5	4.0	25	65	1.25	8	7.3		
B73.8025-150R	8	7.8	3.0	4.0	25	65	1.5	8	7.3		
B73.10030-050R	10	9.8	1.0	2.0	30	75	0.5	10	9.2	●	SP.250-10** SP.5650-10**
B73.10030-075R	10	9.8	1.5	3.0	30	75	0.75	10	9.2		
B73.10030-100R	10	9.8	2.0	3.0	30	75	1.0	10	9.2		
B73.10030-125R	10	9.8	2.5	4.0	25	75	1.25	10	9.2		
B73.10030-150R	10	9.8	3.0	4.0	30	75	1.5	10	9.2		
B73.12040-050R	12	11.7	1.0	2.0	40	85	0.5	12	11	●	SP.250-12** SP.5650-12**
B73.12040-075R	12	11.7	1.5	3.0	40	85	0.75	12	11		
B73.12040-100R	12	11.7	2.0	3.0	40	85	1.0	12	11		
B73.12040-125R	12	11.7	2.5	4.0	25	85	1.25	12	11		
B73.12040-150R	12	11.7	3.0	5.0	40	85	1.5	12	11		
B73.16045-050R	16	15.7	1.0	2.0	45	100	0.5	16	4.7	●	SP.250-16** SP.5650-16**
B73.16045-075R	16	15.7	1.5	3.0	45	100	0.75	16	4.7		
B73.16045-100R	16	15.7	2.0	3.0	45	100	1.0	16	4.7		
B73.16045-125R	16	15.7	2.5	4.0	45	100	1.25	16	4.7		
B73.16045-150R	16	15.7	3.0	5.0	45	100	1.5	16	4.7		
B73.16045-200R	16	15.7	4.0	6.0	45	100	2.0	16	14.7		

無"●"標示者為訂製品。Without "●" marking means custom products.
 有"●"標示者為在庫品。With "●" marking means items in stock.

右向端面圓槽刀 Right hand end face radius turning tool

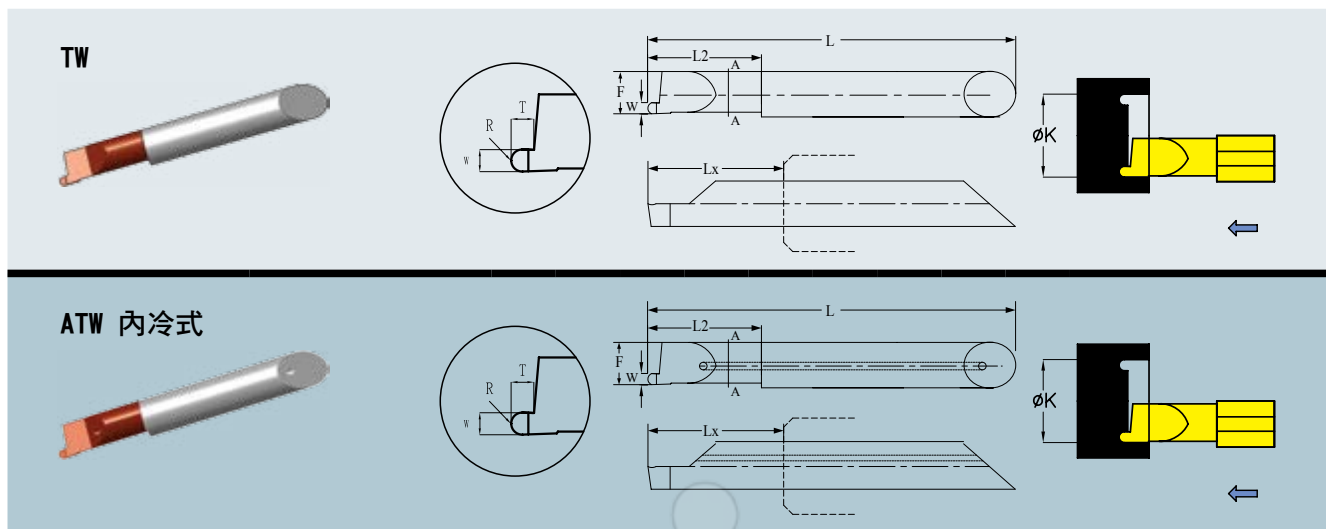

型號 EDP NO.	內冷式 型號 EDP NO.	ØK	F	R _{D.03}	T	L2	Lx	r	ØD	在庫 stock	適用 套筒 Applicable Sleeve
TW B73.4010-050R	ATW B73.4010-050R	4	3.8	1.0	2.0	10	12	0.5	4		SP.380-04**
TW B73.4010-075R	ATW B73.4010-075R	4	3.8	1.5	2.0	10	12	0.75	4		
TW B73.4010-100R	ATW B73.4010-100R	4	3.8	2.0	3.0	10	12	1.0	4		
TW B73.6020-050R	ATW B73.6020-050R	6	5.8	1.0	2.0	20	23	0.5	6		SP.380-06**
TW B73.6020-075R	ATW B73.6020-075R	6	5.8	1.5	3.0	20	23	0.75	6		
TW B73.6020-100R	ATW B73.6020-100R	6	5.8	2.0	3.0	20	23	1.0	6		
TW B73.8025-050R	ATW B73.8025-050R	8	7.8	1.0	2.0	25	28	0.5	8		SP.380-08**
TW B73.8025-075R	ATW B73.8025-075R	8	7.8	1.5	3.0	25	28	0.75	8		
TW B73.8025-100R	ATW B73.8025-100R	8	7.8	2.0	3.0	25	28	1.0	8		
TW B73.8025-125R	ATW B73.8025-125R	8	7.8	2.5	4.0	25	28	1.25	8		
TW B73.8025-150R	ATW B73.8025-150R	8	7.8	3.0	4.0	25	28	1.5	8		

無"●"標示者為訂製品。Without "●" marking means custom products.
 有"●"標示者為在庫品。With "●" marking means items in stock.