

# 鎢鋼 2刃球形立銑刀

## TUNGSTEN CARBIDE 2-FLUTE BALL END MILL

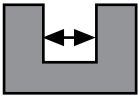

$3 < d \leq 6$  -0.015 ~ -0.038  
 $6 < d \leq 18$  -0.020 ~ -0.047  
 $18 < d$  -0.020 ~ -0.053



$R = \pm 0.02$

- 超細微粒碳化鎢材質
- Micro-Grain Tungsten Carbide

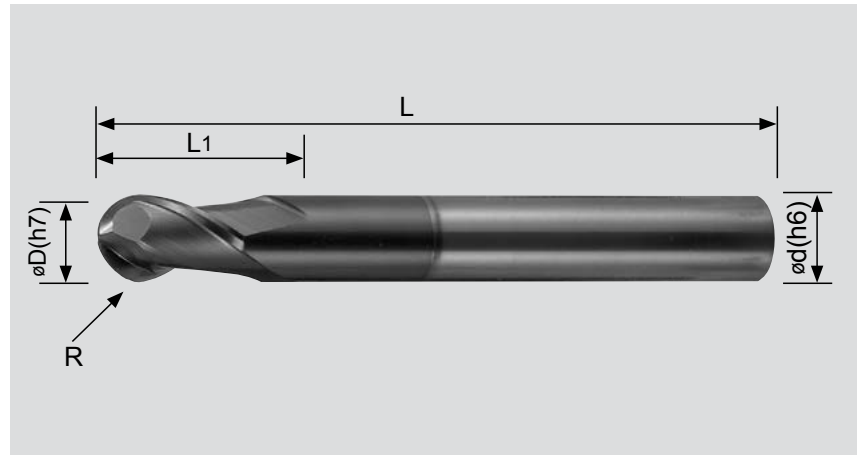

### 適合材質：

鐵材、碳素鋼、鑄鐵、模具鋼、合金鋼、  
工具鋼、不鏽鋼、熱處理鋼、焊補鋼料。

### Applicable materials:

Ferrous metal, carbon steel,  
cast iron, mold steel, alloy steel, tool steel,  
stainless steel, heat-treated steel, welded steel.

單位/Unit : mm

型號 EDP NO.	刃徑 D Flute Dia.	R徑 Radius	刃長 L1 Length of Cut	全長 L Overall Length	柄徑 d Shank Diameter	刃數 Flute Number	AK35	AK925	PK66
62BE-R0.5L39	1.0	R 0.5	2.0	39	3.0	2	●		●
62BE-R0.75L39	1.5	R 0.75	3.0	39	3.0	2	●		●
62BE-R1.0L39	2.0	R 1.0	4.0	39	3.0	2	●		●
62BE-R1.25L39	2.5	R 1.25	6.0	39	3.0	2	●		●
62BE-R1.5L39	3.0	R 1.5	6.0	39	3.0	2	●		●
62BE-R2.0L51	4.0	R 2.0	8.0	51	4.0	2	●	●	●
62BE-R2.5L51	5.0	R 2.5	10.0	51	5.0	2	●	●	●
62BE-R3.0L63	6.0	R 3.0	12.0	63	6.0	2	●	●	●
62BE-R4.0L63	8.0	R 4.0	16.0	63	8.0	2	●	●	●
62BE-R5.0L75	10.0	R 5.0	20.0	75	10.0	2	●	●	●
62BE-R6.0L75	12.0	R 6.0	24.0	75	12.0	2	●	●	●
62BEL-R1.0L100	3.0	R 1.5	6.0	100	3.0	2	●	●	●
62BEL-R2.0L100	4.0	R 2.0	8.0	100	4.0	2	●	●	●
62BEL-R2.5L100	5.0	R 2.5	10.0	100	5.0	2	●	●	●
62BEL-R3.0L100	6.0	R 3.0	12.0	100	6.0	2	●	●	●
62BEL-R4.0L100	8.0	R 4.0	16.0	100	8.0	2	●	●	●
62BEL-R5.0L100	10.0	R 5.0	20.0	100	10.0	2	●	●	●
62BEL-R6.0L100	12.0	R 6.0	24.0	100	12.0	2	●	●	●
62BEL-R8.0L100	16.0	R 8.0	32.0	100	16.0	2	●	●	●

註: 有●者表示有庫存  
NOTE: ● means items in stock

切削條件表請參考第74頁