

鎢鋼 2刃球形立銑刀

TUNGSTEN CARBIDE 2-FLUTE BALL END MILL



	$3 < d \leq 6$ -0.015 ~ -0.038
	$6 < d \leq 18$ -0.020 ~ -0.047
	$18 < d$ -0.020 ~ -0.053

	$R = \pm 0.02$
--	----------------

- 超細微粒碳化鎢材質
- Micro-Grain Tungsten Carbide

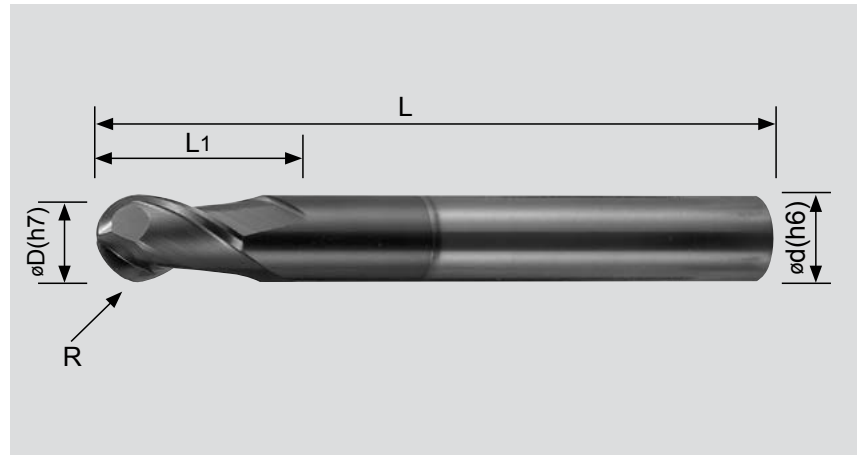

適合材質：

鐵材、碳素鋼、鑄鐵、模具鋼、合金鋼、
工具鋼、不鏽鋼、熱處理鋼、焊補鋼料。

Applicable materials:

Ferrous metal, carbon steel,
cast iron, mold steel, alloy steel, tool steel,
stainless steel, heat-treated steel, welded steel.

單位/Unit : mm

型號 EDP NO.	刃徑 D Flute Dia.	R徑 Radius	刃長 L1 Length of Cut	全長 L Overall Length	柄徑 d Shank Diameter	刃數 Flute Number	AK45	PK66
2BE-R0.5L50	1.0	R 0.5	2.0	50	4.0	2	●	●
2BE-R0.75L50	1.5	R 0.75	3.0	50	4.0	2	●	●
2BE-R1.0L50	2.0	R 1.0	4.0	50	4.0	2	●	●
2BE-R1.5L50	3.0	R 1.5	6.0	50	4.0	2	●	●
2BE-R1.5L50	3.0	R 1.5	6.0	50	3.0	2	●	●
2BE-R2.0L50	4.0	R 2.0	8.0	50	4.0	2	●	●
2BE-R2.5L50	5.0	R 2.5	10.0	50	5.0	2	●	●
2BE-R3.0L50	6.0	R 3.0	12.0	50	6.0	2	●	●
2BE-R4.0L75	8.0	R 4.0	16.0	60	8.0	2	●	●
2BE-R5.0L75	10.0	R 5.0	20.0	75	10.0	2	●	●
2BE-R6.0L75	12.0	R 6.0	24.0	75	12.0	2	●	●
2BEL-R1.0L75	2.0	R 1.0	4.0	75	4.0	2	●	●
2BEL-R1.5L75	3.0	R 1.5	6.0	75	4.0	2	●	●
2BEL-R1.5L100	3.0	R 1.5	15.0	100	3.0	2	●	●
2BEL-R2.0L75	4.0	R 2.0	8.0	75	4.0	2	●	●
2BEL-R2.0L100	4.0	R 2.0	20.0	100	4.0	2	●	●
2BEL-R2.5L75	5.0	R 2.5	10.0	75	5.0	2	●	●
2BEL-R2.5L100	5.0	R 2.5	25.0	100	5.0	2	●	●
2BEL-R3.0L100	6.0	R 3.0	30.0	100	6.0	2	●	●
2BEL-R4.0L100	8.0	R 4.0	35.0	100	8.0	2	●	●
2BEL-R5.0L100	10.0	R 5.0	40.0	100	10.0	2	●	●
2BEL-R6.0L100	12.0	R 6.0	50.0	100	12.0	2	●	●

註：有●者表示有庫存

NOTE: ● means items in stock

切削條件表請參考第74頁