

全鎢鋼三刃倒角刀

TUNGSTEN CARBIDE 3-FLUTE CHAMFERING END MILL



鎢鋼材質 高硬度、耐摩耗，鑽頂角90°、120°。

Tungsten Carbide material, high hardness, high wear resistance, point angle 90° or 120°

適用材質：

銅一般鋼料、合金鋼、不鏽鋼、銅、鋁、鑄鐵。

Applicable materials:

General steel, alloy steel, stainless steel, copper, aluminum, cast iron.

型號 EDP NO.	β°	直徑 $\varnothing D$	刃長 L2	全長 L	柄徑 $\varnothing d$	柄徑 $\varnothing d$
3CMF-D4.0L38	90°	4.0	8	38	4.0	4.0
3CMF-D6.0L45	90°	6.0	12	45	6.0	6.0
3CMF-D8.0L50	90°	8.0	15	50	8.0	8.0
3CMFS-D12.0L50-10	90°	12.0	20	50	10.0	10.0
3CMFS-D16.0L50-10	90°	16.0	20	50	10.0	10.0

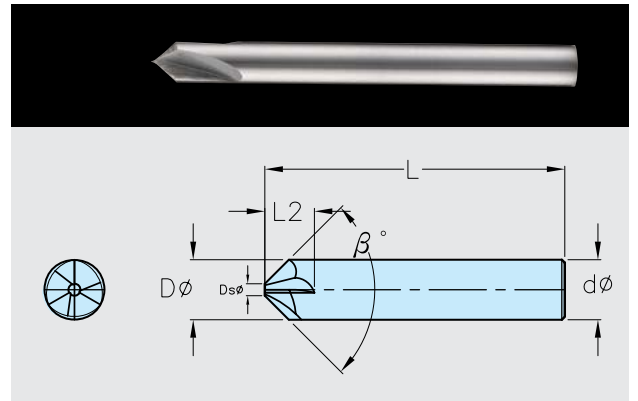

全鎢鋼倒角刀

TUNGSTEN CARBIDE CHAMFERING END MILL

型號 EDP NO.	β°	直徑 $\varnothing D$	全長 L	柄徑 $\varnothing d$	刃數 Z	AK45
4CMFS-6004L38	60°	4.0	38	4.0	4	●
4CMFS-6006L50	60°	6.0	50	6.0	4	●
5CMFS-6008L50	60°	8.0	50	8.0	5	●
6CMFS-6010L50	60°	10.0	50	10.0	6	●
6CMFS-6012L50-10	60°	12.0	50	10.0	6	●

型號 EDP NO.	β°	直徑 $\varnothing D$	全長 L	柄徑 $\varnothing d$	刃數 Z	AK45
4CMFS-9004L38	90°	4.0	38	4.0	4	●
4CMFS-9006L50	90°	6.0	50	6.0	4	●
5CMFS-9008L50	90°	8.0	50	8.0	5	●
6CMFS-9010L50	90°	10.0	50	10.0	6	●
6CMFS-9012L50-10	90°	12.0	50	10.0	6	●

