

# 鎢鋼 4刃圓鼻 重切削立銑刀

## TUNGSTEN CARBIDE 4-FLUTE CORNER RADIUS HEAVY DUTY END MILL

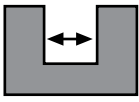

$d \leq 3$  -0.005 ~ -0.028  
 $3 < d \leq 6$  -0.015 ~ -0.038  
 $6 < d \leq 18$  -0.020 ~ -0.047  
 $18 < d$  -0.020 ~ -0.053

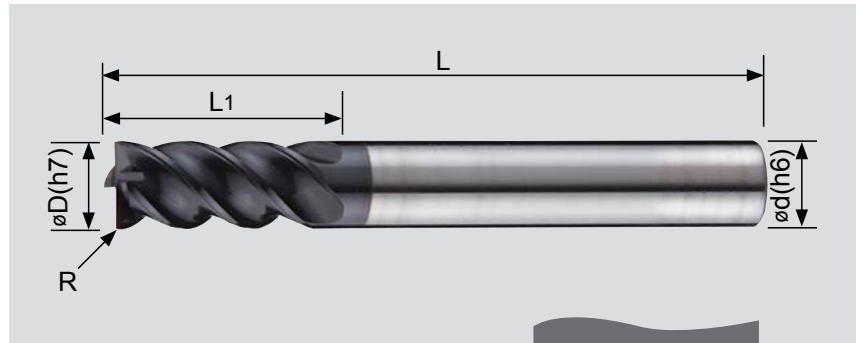

重切削  
Heavy duty

- 超細微粒碳化鎢材質
- Micro-Grain Tungsten Carbide

### 主要特性：

R角結構適合切削高硬度材質，刀尖不易崩裂，並可替代小徑球形銑刀，可作清角和曲面銑削。

### Feature:

The R corner configuration is excellent for cutting high hardness materials without edge collapse. Also, it's replaceable for small radius ball end mill, and permitting for corner cleaning and curving surface milling.

單位/Unit : mm

型號 EDP NO.	刃徑 D Flute Dia.	刃長 L1 Length of Cut	圓角 R Nose R	全長 L Overall Length	柄徑 d Shank Diameter	刃數 Flute Number	AK45
4EHCR-D3.0L50R02	3.0	8.0	0.2	50	6.0	4	●
4EHCR-D3.0L50R05	3.0	8.0	0.5	50	6.0	4	●
4EHCR-D4.0L50R02	4.0	8.0	0.2	50	6.0	4	●
4EHCR-D4.0L50R05	4.0	11.0	0.5	50	6.0	4	●
4EHCR-D4.0L50R10	4.0	11.0	1.0	50	6.0	4	●
4EHCR-D5.0L50R02	5.0	13.0	0.2	50	6.0	4	●
4EHCR-D5.0L50R05	5.0	13.0	0.5	50	6.0	4	●
4EHCR-D5.0L50R10	5.0	13.0	1.0	50	6.0	4	●
4EHCR-D6.0L50R03	6.0	13.0	0.3	50	6.0	4	●
4EHCR-D6.0L50R05	6.0	13.0	0.5	50	6.0	4	●
4EHCR-D6.0L50R10	6.0	13.0	1.0	50	6.0	4	●
4EHCR-D8.0L60R03	8.0	19.0	0.3	60	8.0	4	●
4EHCR-D8.0L60R05	8.0	19.0	0.5	60	8.0	4	●
4EHCR-D8.0L60R10	8.0	19.0	1.0	60	8.0	4	●
4EHCR-D8.0L60R15	8.0	19.0	1.5	60	8.0	4	●
4EHCR-D8.0L60R20	8.0	19.0	2.0	60	8.0	4	●
4EHCR-D10.0L75R03	10.0	22.0	0.3	60	10.0	4	●
4EHCR-D10.0L75R05	10.0	22.0	0.5	75	10.0	4	●
4EHCR-D10.0L75R10	10.0	22.0	1.0	75	10.0	4	●
4EHCR-D10.0L75R15	10.0	22.0	1.5	75	10.0	4	●
4EHCR-D10.0L75R20	10.0	22.0	2.0	75	10.0	4	●
4EHCR-D10.0L75R30	10.0	22.0	3.0	75	10.0	4	●
4EHCR-D12.0L75R05	12.0	26.0	0.5	75	12.0	4	●
4EHCR-D12.0L75R10	12.0	26.0	1.0	75	12.0	4	●
4EHCR-D12.0L75R15	12.0	26.0	1.5	75	12.0	4	●
4EHCR-D12.0L75R20	12.0	26.0	2.0	75	12.0	4	●
4EHCR-D12.0L75R30	12.0	26.0	3.0	75	12.0	4	●
4EHCR-D16.0L80R10	16.0	35.0	1.0	80	16.0	4	●
4EHCR-D16.0L80R15	16.0	35.0	1.5	80	16.0	4	●
4EHCR-D16.0L80R20	16.0	35.0	2.0	80	16.0	4	●
4EHCR-D16.0L80R30	16.0	35.0	3.0	80	16.0	4	●
4EHCR-D20.0L100R10	20.0	40.0	1.0	100	20.0	4	●
4EHCR-D20.0L100R15	20.0	40.0	1.5	100	20.0	4	●
4EHCR-D20.0L100R20	20.0	40.0	2.0	100	20.0	4	●
4EHCR-D20.0L100R30	20.0	40.0	3.0	100	20.0	4	●

請採用剛性較強之側固定式立銑刀架夾持本刀具。  
註：有●者表示有庫存 NOTE: ● means items in stock

切削條件表請參考第90頁