

鎢鋼 4刃斜度立銑刀

TUNGSTEN CARBIDE TAPER 4-FLUTE END MILL

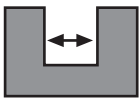

$d \leq 3$ -0.005 ~ -0.028
 $3 < d \leq 6$ -0.015 ~ -0.038
 $6 < d \leq 18$ -0.020 ~ -0.047
 $18 < d$ -0.020 ~ -0.053

- 超細微粒碳化鎢材質
- Micro-Grain Tungsten Carbide

適用材質：

碳素鋼、模具鋼、合金鋼、工具鋼、不鏽鋼、鑄鐵、熱處理鋼。

Applicable material:

Carbon steel, mold steel, alloy steel, tool steel, stainless steel, cast iron, heat-treated steel.

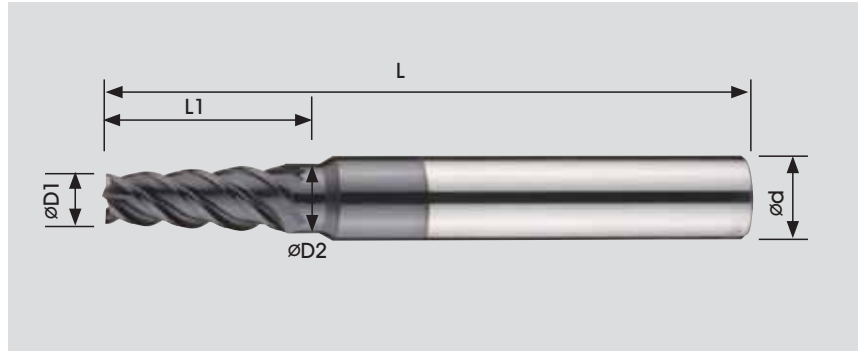

單位: Unit : mm

型號 EDP NO.	刀先徑 D1 Front Flute Dia.	單斜角 Flute Tape	刃長 L1 Length of Cut	大端徑 D2 Rea Flute Di.	全長 L Oveall Length	柄徑 d Shak Diametr	刃數 Flut Nimbe	AK45
4TP-D4.0T05L60	4.0	0.5°	15.0	4.26	60	6.0	4	●
4TP-D4.0T10L60	4.0	1.0°	15.0	4.52	60	6.0	4	●
4TP-D4.0T15L60	4.0	1.5°	15.0	4.79	60	6.0	4	●
4TP-D4.0T20L60	4.0	2.0°	15.0	5.04	60	6.0	4	●
4TP-D4.0T25L60	4.0	2.5°	15.0	5.31	60	6.0	4	●
4TP-D4.0T30L60	4.0	3.0°	15.0	5.57	60	6.0	4	●
4TP-D4.0T50L75	4.0	5.0°	15.0	6.62	75	8.0	4	●
4TP-D4.0T70L75	4.0	7.0°	16.0	8.00	75	8.0	4	●
4TP-D4.0T100L75	4.0	10.0°	17.0	10.00	75	10.0	4	●
4TP-D5.0T05L60	5.0	0.5°	20.0	5.34	60	6.0	4	●
4TP-D5.0T10L60	5.0	1.0°	20.0	5.70	60	6.0	4	●
4TP-D5.0T15L60	5.0	1.5°	19.6	6.00	60	6.0	4	●
4TP-D5.0T20L75	5.0	2.0°	20.0	6.39	75	8.0	4	●
4TP-D5.0T25L75	5.0	2.5°	20.0	6.74	75	8.0	4	●
4TP-D5.0T30L75	5.0	3.0°	20.0	7.10	75	8.0	4	●
4TP-D5.0T50L75	5.0	5.0°	20.0	8.50	75	10.0	4	●
4TP-D5.0T70L75	5.0	7.0°	20.0	10.00	75	10.0	4	●
4TP-D5.0T100L75	5.0	10.0°	20.0	12.00	75	12.0	4	●
4TP-D6.0T05L75	6.0	0.5°	20.0	6.35	75	8.0	4	●
4TP-D6.0T10L75	6.0	1.0°	20.0	6.70	75	8.0	4	●
4TP-D6.0T15L75	6.0	1.5°	20.0	7.05	75	8.0	4	●
4TP-D6.0T20L75	6.0	2.0°	20.0	7.40	75	8.0	4	●
4TP-D6.0T25L75	6.0	2.5°	20.0	7.75	75	8.0	4	●
4TP-D6.0T30L75	6.0	3.0°	20.0	8.10	75	10.0	4	●
4TP-D6.0T50L75	6.0	5.0°	24.0	9.50	75	10.0	4	●
4TP-D6.0T70L80	6.0	7.0°	22.0	12.00	80	12.0	4	●
4TP-D6.0T100L80	6.0	10.0°	25.0	14.00	80	16.0	4	●
4TP-D8.0T05L75	8.0	0.5°	25.0	8.44	75	10.0	4	●
4TP-D8.0T10L75	8.0	1.0°	25.0	8.87	75	10.0	4	●
4TP-D8.0T15L75	8.0	1.5°	25.0	9.31	75	10.0	4	●
4TP-D8.0T20L75	8.0	2.0°	25.0	9.75	75	10.0	4	●
4TP-D8.0T30L75	8.0	3.0°	25.0	10.62	75	12.0	4	●
4TP-D8.0T50L80	8.0	5.0°	25.0	12.37	80	16.0	4	●
4TP-D8.0T70L100	8.0	7.0°	32.0	16.00	100	16.0	4	●
4TP-D8.0T100L100	8.0	10.0°	28.0	18.00	100	18.0	4	●
4TP-D10.0T05L100	10.0	0.5°	35.0	10.61	100	12.0	4	●
4TP-D10.0T10L100	10.0	1.0°	35.0	11.22	100	12.0	4	●
4TP-D10.0T15L100	10.0	1.5°	35.0	11.83	100	12.0	4	●
4TP-D10.0T20L100	10.0	2.0°	35.0	13.06	100	16.0	4	●
4TP-D10.0T30L100	10.0	3.0°	35.0	13.67	100	16.0	4	●
4TP-D10.0T50L100	10.0	5.0°	34.0	16.00	100	16.0	4	●

註: 有●者表示有庫存 NOTE: ● means items in stock

切削條件表請參考第38頁