

鎢鋼 2刃斜度立銑刀

TUNGSTEN CARBIDE TAPER 2-FLUTE END MILL

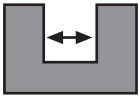

$d \leq 3$ -0.005 ~ -0.028
 $3 < d \leq 6$ -0.015 ~ -0.038
 $6 < d \leq 18$ -0.020 ~ -0.047
 $18 < d$ -0.020 ~ -0.053

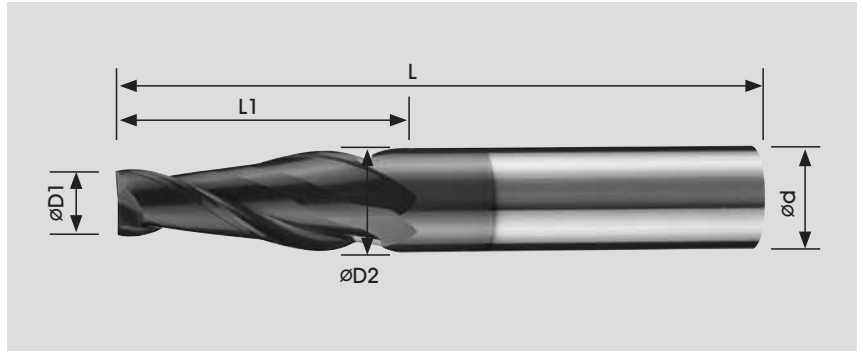

- 超細微粒碳化鎢材質
- Micro-Grain Tungsten Carbide

適用材質：

碳素鋼、模具鋼、合金鋼、工具鋼、不鏽鋼、鑄鐵、熱處理鋼。

Applicable materials:

Carbon steel, mold steel, alloy steel, tool steel, cast iron, stainless steel, heat-treated steel.

單位: Unit : mm

型號 EDP NO.	刀先徑 D1 Front Flute Dia.	單斜角 Flute Taper	刃長 L1 Length of Cut	大端徑 D2 Rear Flute Dia.	全長 L Overall Length	柄徑 d Shank Diameter	2刃數 Flute Number	AK45
2TP-D1.0T05L50	1.0	0.5°	4.0	1.07	50	4.0	2	●
2TP-D1.0T10L50	1.0	1.0°	4.0	1.14	50	4.0	2	●
2TP-D1.0T15L50	1.0	1.5°	4.0	1.21	50	4.0	2	●
2TP-D1.0T20L50	1.0	2.0°	4.0	1.28	50	4.0	2	●
2TP-D1.0T25L50	1.0	2.5°	4.0	1.35	50	4.0	2	●
2TP-D1.0T30L50	1.0	3.0°	4.0	1.42	50	4.0	2	●
2TP-D1.0T50L50	1.0	5.0°	4.0	1.70	50	4.0	2	●
2TP-D1.5T05L50	1.5	0.5°	5.0	1.59	50	4.0	2	●
2TP-D1.5T10L50	1.5	1.0°	5.0	1.68	50	4.0	2	●
2TP-D1.5T15L50	1.5	1.5°	5.0	1.76	50	4.0	2	●
2TP-D1.5T20L50	1.5	2.0°	5.0	1.85	50	4.0	2	●
2TP-D1.5T25L50	1.5	2.5°	5.0	1.93	50	4.0	2	●
2TP-D1.5T30L50	1.5	3.0°	5.0	2.02	50	4.0	2	●
2TP-D1.5T50L50	1.5	5.0°	5.0	2.37	50	4.0	2	●
2TP-D2.0T05L50	2.0	0.5°	6.0	2.10	50	4.0	2	●
2TP-D2.0T10L50	2.0	1.0°	6.0	2.21	50	4.0	2	●
2TP-D2.0T15L50	2.0	1.5°	6.0	2.31	50	4.0	2	●
2TP-D2.0T20L50	2.0	2.0°	6.0	2.41	50	4.0	2	●
2TP-D2.0T25L50	2.0	2.5°	6.0	2.52	50	4.0	2	●
2TP-D2.0T30L50	2.0	3.0°	6.0	2.62	50	4.0	2	●
2TP-D2.0T50L50	2.0	5.0°	6.0	3.05	50	4.0	2	●
2TP-D2.5T05L50	2.5	0.5°	8.0	2.64	50	4.0	2	●
2TP-D2.5T10L50	2.5	1.0°	8.0	2.78	50	4.0	2	●
2TP-D2.5T15L50	2.5	1.5°	8.0	2.91	50	4.0	2	●
2TP-D2.5T20L50	2.5	2.0°	8.0	3.05	50	4.0	2	●
2TP-D2.5T25L50	2.5	2.5°	8.0	3.20	50	4.0	2	●
2TP-D2.5T30L50	2.5	3.0°	8.0	3.33	50	4.0	2	●
2TP-D2.5T50L50	2.5	5.0°	8.0	3.90	50	4.0	2	●
2TP-D3.0T05L50	3.0	0.5°	10.0	3.17	50	6.0	2	●
2TP-D3.0T10L50	3.0	1.0°	10.0	3.35	50	6.0	2	●
2TP-D3.0T15L50	3.0	1.5°	10.0	3.52	50	6.0	2	●
2TP-D3.0T20L50	3.0	2.0°	10.0	6.69	50	6.0	2	●
2TP-D3.0T25L50	3.0	2.5°	10.0	3.87	50	6.0	2	●
2TP-D3.0T30L50	3.0	3.0°	10.0	4.05	50	6.0	2	●
2TP-D3.0T50L50	3.0	5.0°	10.0	4.75	50	6.0	2	●
2TP-D3.0T70L50	3.0	7.0°	10.0	6.00	50	6.0	2	●
2TP-D3.0T100L60	3.0	10.0°	10.0	6.52	60	8.0	2	●

註: 有●者表示有庫存

NOTE: ● means items in stock

切削條件表請參考第38頁