

鎢鋼 6,8刃立銑刀

TUNGSTEN CARBIDE 6,8-FLUTE END MILL

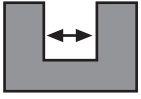

$d \leq 3$ -0.005 ~ -0.028
 $3 < d \leq 6$ -0.015 ~ -0.038
 $6 < d \leq 18$ -0.020 ~ -0.047
 $18 < d$ -0.020 ~ -0.053

- 超細微粒碳化鎢材質
- Micro-Grain Tungsten Carbide

適合材質：

碳素鋼、模具鋼、合金鋼、工具鋼、
不鏽鋼、鑄鐵、熱處理鋼料、焊補鋼料。

Applicable material:

Carbon steel, mold steel, alloy steel,
tool steel, cast iron, stainless steel,
heat-treated steel, welded steel.

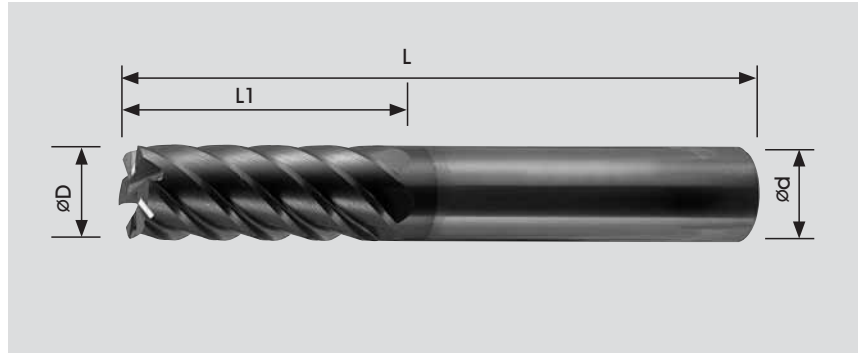

單位: Unit : mm

| 型號 EDP NO. | 刃徑 D Flute Dia. | 刃長 L1 Length of Cut | 全長 L Overall Length | 柄徑 d Shank Diameter | 刃數 Flute Number | AK45 | AK925 |
|---------------|--------------------|------------------------|------------------------|------------------------|--------------------|------|-------|
| 6E-D6.0L60 | 6.0 | 15.0 | 60 | 6.0 | 6 | ● | ● |
| 6E-D8.0L75 | 8.0 | 25.0 | 75 | 8.0 | 6 | ● | ● |
| 6E-D10.0L75 | 10.0 | 25.0 | 75 | 10.0 | 6 | ● | ● |
| 6E-D12.0L75 | 12.0 | 30.0 | 75 | 12.0 | 6 | ● | ● |
| 6E-D16.0L100 | 16.0 | 45.0 | 100 | 16.0 | 6 | ● | ● |
| 8E-D20.0L100 | 20.0 | 45.0 | 100 | 20.0 | 8 | ● | ● |
| 8E-D25.0L100 | 25.0 | 45.0 | 100 | 25.0 | 8 | ● | ● |

註: 有●者表示有庫存

NOTE: ● means items in stock

切削條件表請參考第42頁