

鎢鋼 3刃立銑刀

TUNGSTEN CARBIDE 3-FLUTE SQUARE END MILL



| | |
|-----------------|-----------------|
| $d \leq 3$ | -0.005 ~ -0.028 |
| $3 < d \leq 6$ | -0.015 ~ -0.038 |
| $6 < d \leq 18$ | -0.020 ~ -0.047 |
| $18 < d$ | -0.020 ~ -0.053 |

- 超細微粒碳化鎢材質
- Micro-Grain Tungsten Carbide

適用材質：

碳素鋼、模具鋼、合金鋼、

工具鋼、鑄鐵、不鏽鋼、

熱處理鋼、焊補鋼料。

Applicable materials:

Carbon steel, mold steel,

alloy steel, tool steel, cast iron, stainless steel,

heat-treated steel, welded steel.

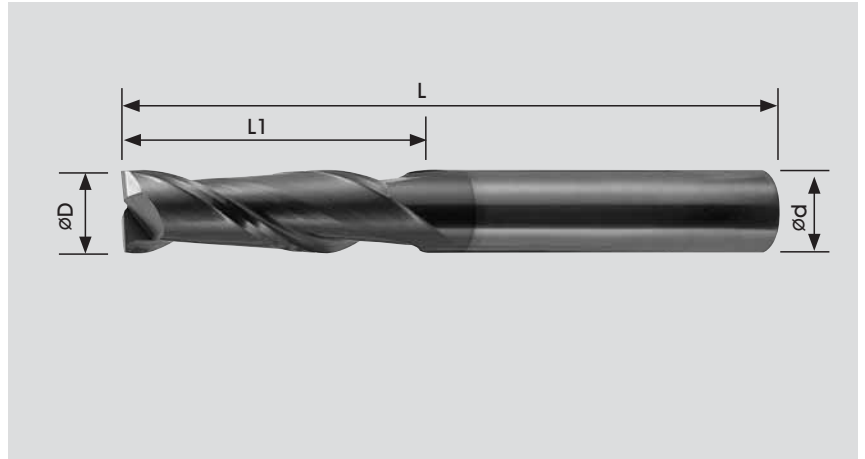

單位: Unit : mm

| 型號 EDP NO. | 刃徑 D Flute Dia. | 刃長 L1 Length of Cut | 全長 L Overall Length | 柄徑 d Shank Diameter | 刃數 Flute Number | AK45 | AK925 | PK66 |
|---------------|--------------------|------------------------|------------------------|------------------------|--------------------|------|-------|------|
| 3E-D3.0L50 | 3.0 | 8.0 | 50 | 4.0 | 3 | ● | ● | ● |
| 3E-D4.0L50 | 4.0 | 10.0 | 50 | 4.0 | 3 | ● | ● | ● |
| 3E-D3.0L50-6 | 3.0 | 8.0 | 50 | 6.0 | 3 | ● | ● | ● |
| 3E-D4.0L50-6 | 4.0 | 10.0 | 50 | 6.0 | 3 | ● | ● | ● |
| 3E-D5.0L50 | 5.0 | 13.0 | 50 | 6.0 | 3 | ● | ● | ● |
| 3E-D6.0L50 | 6.0 | 15.0 | 50 | 6.0 | 3 | ● | ● | ● |
| 3E-D7.0L60 | 7.0 | 20.0 | 60 | 8.0 | 3 | ● | ● | ● |
| 3E-D8.0L60 | 8.0 | 20.0 | 60 | 8.0 | 3 | ● | ● | ● |
| 3E-D10.0L75 | 10.0 | 25.0 | 75 | 10.0 | 3 | ● | ● | ● |
| 3E-D12.0L75 | 12.0 | 30.0 | 75 | 12.0 | 3 | ● | ● | ● |
| 3E-D14.0L75 | 14.0 | 35.0 | 75 | 14.0 | 3 | ● | ● | ● |
| 3E-D16.0L100 | 16.0 | 45.0 | 100 | 16.0 | 3 | ● | ● | ● |

註: 有●者表示有庫存

切削條件表請參考第37頁

NOTE: ● means items in stock