

鎢鋼 2刃球形立銑刀

TUNGSTEN CARBIDE 2-FLUTE BALL END MILL



	$3 < d \leq 6$	-0.015 ~ -0.038
	$6 < d \leq 18$	-0.020 ~ -0.047
	$18 < d$	-0.020 ~ -0.053

	$R = \pm 0.02$
--	----------------

- 超細微粒碳化鎢材質
- Micro-Grain Tungsten Carbide

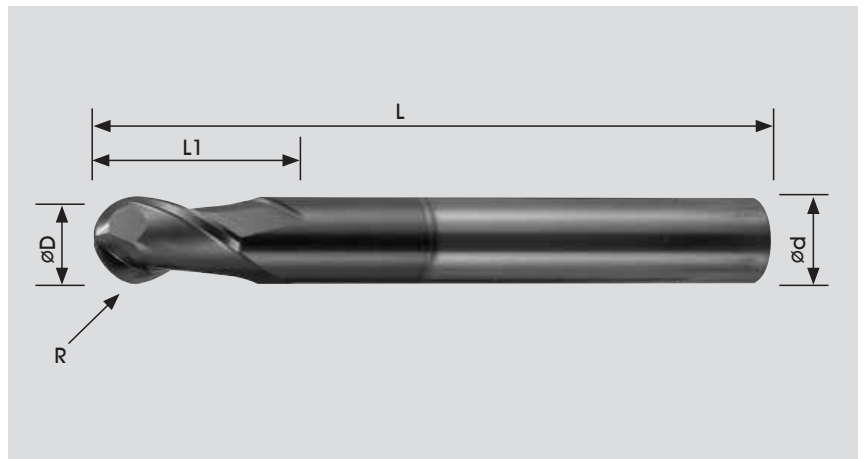

適用材質：

鐵材、碳素鋼、鑄鐵、模具鋼、
合金鋼、工具鋼、不鏽鋼、
熱處理鋼、焊補鋼料。

Applicable materials:

Ferrous metal, carbon steel,
cast iron, mold steel, alloy steel, tool steel,
stainless steel, heat-treated steel, welded steel.

單位: Unit : mm

型號 EDP NO.	直徑 DØ	圓徑 R	刃長 L2	全長 L Overall Length	柄徑 d Shank Diameter	刃數 Flute Number	AK45
2BES-R0.5L38	1.0	0.5	2.0	38	3.0	2	●
2BES-R0.75L38	1.5	0.75	3.0	38	3.0	2	●
2BES-R1.0L38	2.0	1.0	4.0	38	3.0	2	●
2BES-R1.25L38	2.5	1.25	5.0	38	3.0	2	●
2BES-R1.5L38	3.0	1.5	6.0	38	3.0	2	●
2BE-R2.0L50	4.0	2.0	8.0	50	4.0	2	●
2BE-R2.5L50	5.0	2.5	10.0	50	6.0	2	●
2BE-R3.0L50	6.0	3.0	12.0	50	6.0	2	●
2BE-R3.5L50	7.0	3.5	15.0	50	8.0	2	●
2BE-R4.0L50	8.0	4.0	15.0	50	8.0	2	●
2BE-R4.5L50	9.0	4.5	15.0	50	10.0	2	●
2BE-R5.0L50	10.0	5.0	15.0	50	10.0	2	●
2BE-R6.0L50-10	12.0	6.0	15.0	50	10.0	2	●

註:有●者表示有庫存 NOTE:●means items in stock