

鎢鋼2刃點數型立銑刀

TUNGSTEN CARBIDE 2FLUTE DECIMAL END MILL

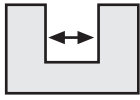

$d \leq 3$ -0.005 ~ -0.028
 $3 < d \leq 6$ -0.015 ~ -0.038
 $6 < d \leq 18$ -0.020 ~ -0.047
 $18 < d$ -0.020 ~ -0.053

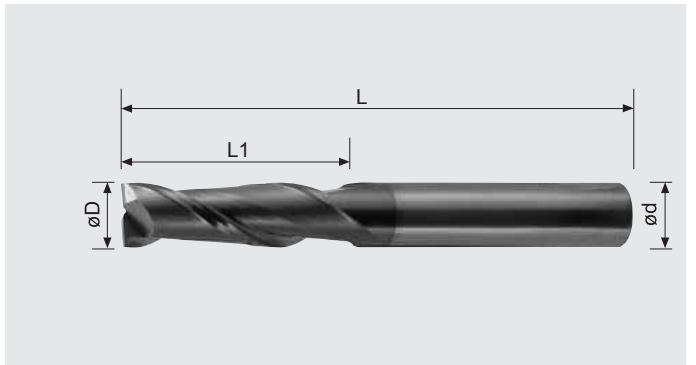

- 超細微粒碳化材質
- Micro-Grain Tungsten Carbide

適合材質：

碳素鋼、模具鋼、合金鋼、工具鋼、不鏽鋼、鑄鐵、熱處理鋼料、焊補鋼料

Applicable materials:

Carbon steel, mold steel, alloy steel, cast iron, stainless steel, heat treated steel, welded steel.

單位:Unit: mm

型號 EDP NO.	直徑 DØ	刃長 L1 Length of Cut	全長 L Overall Length	柄徑 d Shank Diameter	刃數 Flute Number	AK45
2ES-D1.1L38	1.1	3	38	3.0	2	●
2ES-D1.2L38	1.2	3	38	3.0	2	●
2ES-D1.3L38	1.3	3	38	3.0	2	●
2ES-D1.4L38	1.4	4	38	3.0	2	●
2ES-D1.5L38	1.5	4	38	3.0	2	●
2ES-D1.6L38	1.6	4	38	3.0	2	●
2ES-D1.7L38	1.7	5	38	3.0	2	●
2ES-D1.8L38	1.8	5	38	3.0	2	●
2ES-D1.9L38	1.9	5	38	3.0	2	●
2ES-D2.0L38	2.0	5	38	3.0	2	●

型號 EDP NO.	直徑 DØ	刃長 L1 Length of Cut	全長 L Overall Length	柄徑 d Shank Diameter	刃數 Flute Number	AK45
2ES-D1.0L38	1.0	3.0	38	3.0	2	●
2ES-D1.5L38	1.5	4.0	38	3.0	2	●
2ES-D2.0L38	2.0	6.0	38	3.0	2	●
2ES-D2.5L38	2.5	7.0	38	3.0	2	●
2ES-D3.0L38	3.0	8.0	38	3.0	2	●
2ES-D3.5L38	3.5	10.0	40	4.0	2	●
2E-D4.0L50	4.0	12.0	50	4.0	2	●
2E-D4.5L50	4.5	13.0	50	6.0	2	●
2E-D5.0L50	5.0	13.0	50	6.0	2	●
2E-D6.0L50	6.0	15.0	50	6.0	2	●
2ES-D7.0L50	7.0	15.0	50	8.0	2	●
2ES-D8.0L50	8.0	15.0	50	8.0	2	●
2E-D9.0L50	9.0	15.0	50	10.0	2	●
2ES-D10.0L50	10.0	15.0	50	10.0	2	●
2ES-D12.0L50-10	12.0	15.0	50	10.0	2	●

型號 EDP NO.	直徑 DØ	刃長 L1 Length of Cut	全長 L Overall Length	柄徑 d Shank Diameter	刃數 Flute Number	AK45
3ES-D2.0L38	3.0	6.0	38	3.0	3	●
3ES-D2.5L38	3.0	7.0	38	3.0	3	●
3ES-D3.0L38	3.0	8.0	38	3.0	3	●
3E-D4.0L50	4.0	12.0	50	4.0	3	●
3E-D5.0L50	5.0	13.0	50	6.0	3	●
3E-D6.0L50	6.0	15.0	50	6.0	3	●
3ES-D8.0L50	8.0	15.0	50	8.0	3	●
3ES-D10.0L50	10.0	15.0	50	10.0	3	●
3ES-D12.0L50-10	12.0	15.0	50	10.0	3	●

註:有●者表示有庫存 NOTE:●means items in stock