

鎢鋼 4刃重切削立銑刀

TUNGSTEN CARBIDE 4-FLUTE HEAVY DUTY END MILL



$d \leq 3$ -0.005 ~ -0.028
 $3 < d \leq 6$ -0.015 ~ -0.038
 $6 < d \leq 18$ -0.020 ~ -0.047
 $18 < d$ -0.020 ~ -0.053

- 超細微粒碳化鎢材質
- Micro-Grain Tungsten Carbide

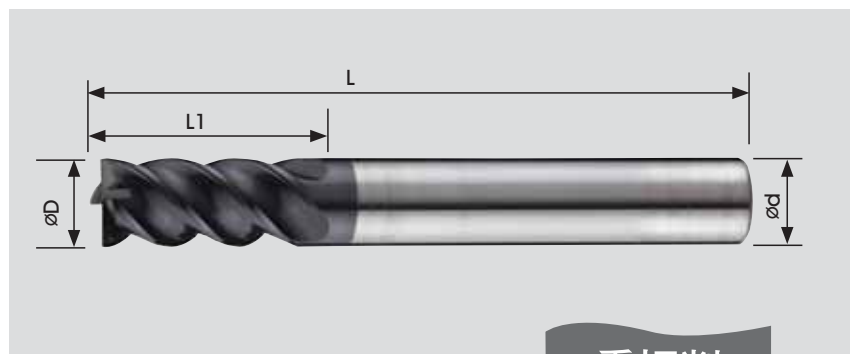

重切削
Heavy duty

AK-45

Tungsten Carbide 0.5 μ m

Co12% WC86.7% TC/Ta(Nb)C 1.3%

單位: Unit : mm

型號 EDP NO.	刃徑 D Flute Dia.	刃長 L1 Length of Cut	全長 L Overall Length	柄徑 d Shank Diameter	刃數 Flute Number	AK45
4EHS-D3.0L50	3.0	4.5	50	6.0	4	
4EHS-D4.0L50	4.0	6.0	50	6.0	4	
4EHS-D5.0L50	5.0	7.5	50	6.0	4	
4EHS-D6.0L50	6.0	9.0	50	6.0	4	
4EHS-D8.0L60	8.0	12.0	60	8.0	4	
4EHS-D10.0L75	10.0	15.0	75	10.0	4	
4EHS-D12.0L75	12.0	18.0	75	12.0	4	
4EHS-D16.0L100	16.0	24.0	100	16.0	4	
4EHS-D20.0L100	20.0	30.0	100	20.0	4	
4EH-D3.0L60	3.0	8.0	60	6.0	4	●
4EH-D4.0L60	4.0	11.0	60	6.0	4	●
4EH-D5.0L60	5.0	13.0	60	6.0	4	●
4EH-D6.0L60	6.0	13.0	60	6.0	4	●
4EH-D8.0L60	8.0	19.0	60	8.0	4	●
4EH-D10.0L75	10.0	22.0	75	10.0	4	●
4EH-D12.0L75	12.0	26.0	75	12.0	4	●
4EH-D16.0L100	16.0	35.0	100	16.0	4	●
4EH-D20.0L100	20.0	40.0	100	20.0	4	●
4EHM-D3.0L60	3.0	12.0	60	6.0	4	●
4EHM-D4.0L60	4.0	16.0	60	6.0	4	●
4EHM-D5.0L60	5.0	18.0	60	6.0	4	●
4EHM-D6.0L60	6.0	20.0	60	6.0	4	●
4EHM-D8.0L60	8.0	25.0	75	8.0	4	●
4EHM-D10.0L75	10.0	30.0	75	10.0	4	●
4EHM-D12.0L75	12.0	35.0	100	12.0	4	●
4EHM-D16.0L100	16.0	45.0	110	16.0	4	●
4EHM-D20.0L100	20.0	50.0	125	20.0	4	●
4EHL-D3.0L60	3.0	15.0	60	6.0	4	●
4EHL-D4.0L60	4.0	20.0	60	6.0	4	●
4EHL-D5.0L60	5.0	22.0	60	6.0	4	●
4EHL-D6.0L75	6.0	25.0	75	6.0	4	●
4EHL-D8.0L75	8.0	30.0	75	8.0	4	●
4EHL-D10.0L80	10.0	35.0	80	10.0	4	●
4EHL-D12.0L100	12.0	40.0	100	12.0	4	●
4EHL-D16.0L110	16.0	55.0	110	16.0	4	●
4EHL-D20.0L125	20.0	60.0	125	20.0	4	●

請採用剛性較強之側固定式立銑刀架挾持本刀具。
註: 有●者表示有庫存 NOTE: ● means items in stock

切削條件表請參考第40頁